

# Pyroguard Infinity

Technical guidance document

# Contents

1	Introduction.....	2
2	Summary of Pyroguard Infinity glass types.....	4
3	Summary of approvals .....	5
4	Specification and ordering of SWS joints.....	6
4.1	Z, R, U or STD? .....	6
4.2	Handedness.....	6
4.3	Dimensions .....	7
5	Installation .....	9
5.1	Pyroguard T installation instructions.....	9
5.2	Pyroguard EI (aka Pyroguard Rapide Plus) installation instructions .....	11
5.2.1	Handling instructions .....	13
5.2.2	Recommendations when taping the edges .....	14
5.3	Choosing sealants .....	14
5.3.1	Dowsil 121 Structural Glazing Sealant (DOW CORNING) .....	14
5.3.2	Dowsil 895 High Quality Structural Glazing Sealant (DOW CORNING).....	14
5.3.3	Kerafix® Fire Rated Silicone (KunhOdice UK Ltd).....	15
5.4	Two cloth cleaning method (ref 'Dow Corning Americas Technical Manual') .....	15
6	Disclaimer.....	16
7	Warranty.....	17

# 1 Introduction

This document summarises the installation details for Pyroguard Infinity Structural Wall System (SWS) products. Not all information is valid in all regions.

The following terms are used:

RV – Double Sided “Recto Verso”

SWS – Structural Wall System

T – Toughened

TVI – Triple Glazed Unit “Triple Vitrage Isolant”

VI – Double Glazed Unit “Vitrage Isolant”

VF – Laminated “Vitrage Feuilleté”

The Pyroguard Infinity range consists of two product types: Pyroguard T SWS and Pyroguard EI.

Pyroguard T SWS is a toughened nanocomposite gel laminate with a black edge seal 13 mm thick. Pyroguard EI is an annealed glass sodium silicate waterglass laminate, this product is cuttable and stockable.

Users of this document should consult the original approvals before proceeding to specification and installation. In general, the constructions detailed in this document may be installed as ‘infinite’ screens; they may be repeated without restriction (see Figure 1). The approved height of the construction is directly related to the approved height of the glazing, plus the necessary framing.

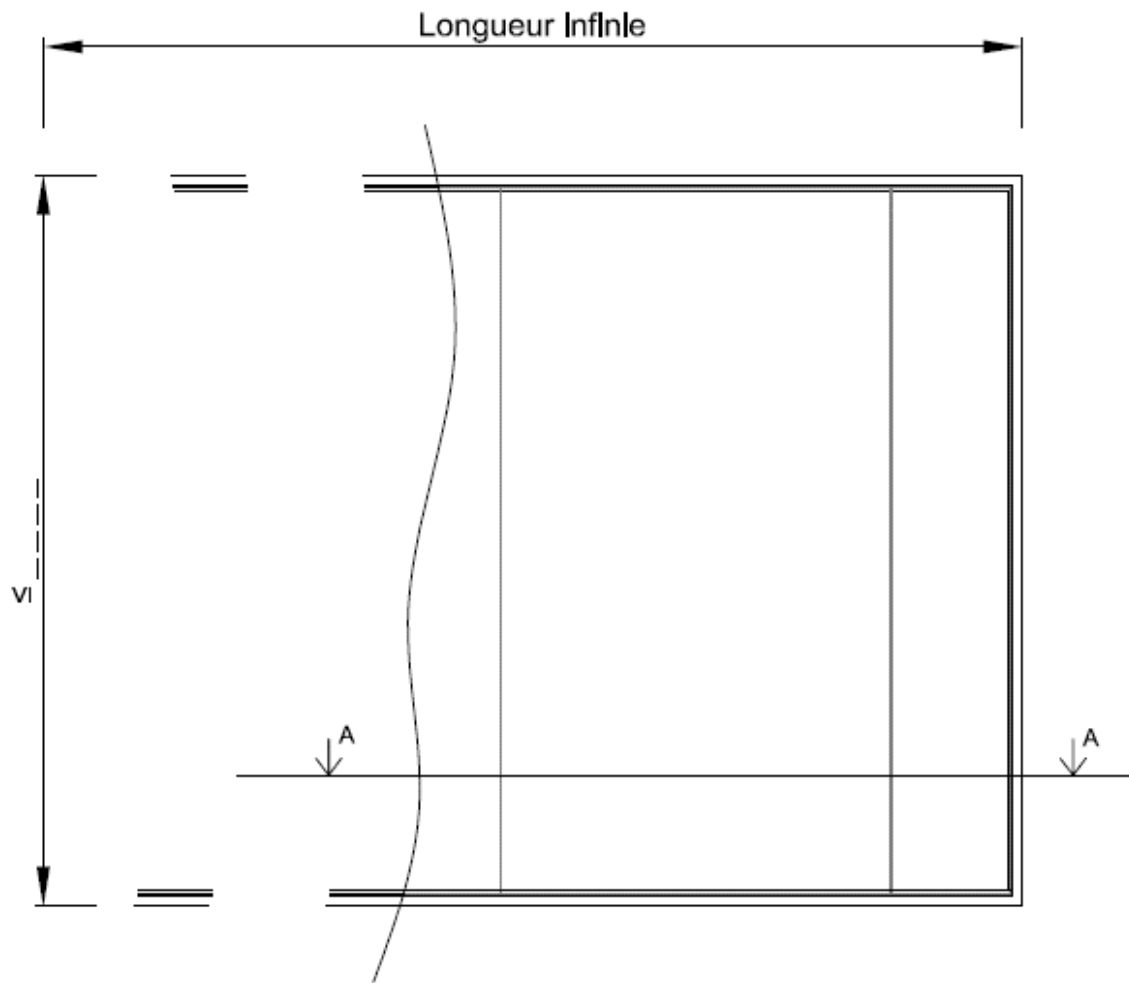

Figure 1 Illustration of a repeating SWS partition

## 2 Summary of Pyroguard Infinity glass types

The following table describes the product types available under the Pyroguard Infinity brand in summary. Note the different seals required for the glass-glass joint.

<b>Pyroguard Infinity</b>	
<b>Pyroguard EI (aka Pyroguard Rapide Plus)</b>	<b>Pyroguard T</b>
Pyroguard EI30 INT SWS (15 mm)	Pyroguard T-EI30/24-2 SWS (24 mm)
Pyroguard EI30 EXT SWS (19 mm)	Pyroguard T-EI30/32-2 SWS (32 mm)
Pyroguard EI60 INT SWS (23 mm)	Pyroguard T-EI60/32-2 SWS (32 mm)
Pyroguard EI60 EXT SWS (27 mm)	Pyroguard T-EI60/36-3 SWS (36 mm)
Pyroguard EI60 EXT+ SWS (31 mm)	Pyroguard T-EI90/36-3 SWS (36 mm)
Pyroguard EI60 EXT++ SWS (34 mm)	Pyroguard T-EI90/47-3 SWS (47 mm)
	Pyroguard T-EI90/39-3 SWS (39 mm)
	Pyroguard T-EI120/58-4 SWS (58 mm)
<b>Characteristics</b>	
Cuttable	Toughened, bespoke sizes
Aluminium edge taping required trimmed back on the butt joint edge	Edge seal of 13 mm visible on each pane
<b>Glass-Glass Joint Seals</b>	
Interdens (KuhnOdice)	Palusol (KuhnOdice) aka Pyrostrip 100 ECSA (KuhnOdice)
Kerafix Fire Rated Silicone (KuhnOdice)	Dowsil 895 (Dow Corning)
<b>Glazing seals on beads and in rebate</b>	
Consult the approvals	

## 3 Summary of approvals

For access to approval of Pyroguard Infinity please request access to the Pyroguard TechLibrary (<https://techlibrary.pyroguard.eu:5443/index.php/login>).

When designing and installing it is important to respect the following key elements:

- Maximum pane size and maximum area
- Maximum partition height
- Approved support structures
- Approved ancillary components
  - Glazing tape
  - Specified intumescent in the glass-glass joint
  - Specified silicone sealant in the glass-glass joint

Further relevant guidance is available in the following documents which can be found here:

<https://www.pyroguard.eu/downloads/our-guidance-documentation/>:

- Pyroguard Vision System Guidance
- Pyroguard Rapide Plus SWS Guidance Document
- Care and Cleaning Instructions

# 4 Specification and ordering of SWS joints

## 4.1 Z, R, U or STD?

Of the construction types shown below in Figure 2 only std, and r, can be made with Pyroguard T type and only std with Pyroguard EI type.

z and u are not easily produced or shipped to site because they have no flat long edge to stand on and should be avoided (see Figure 2).

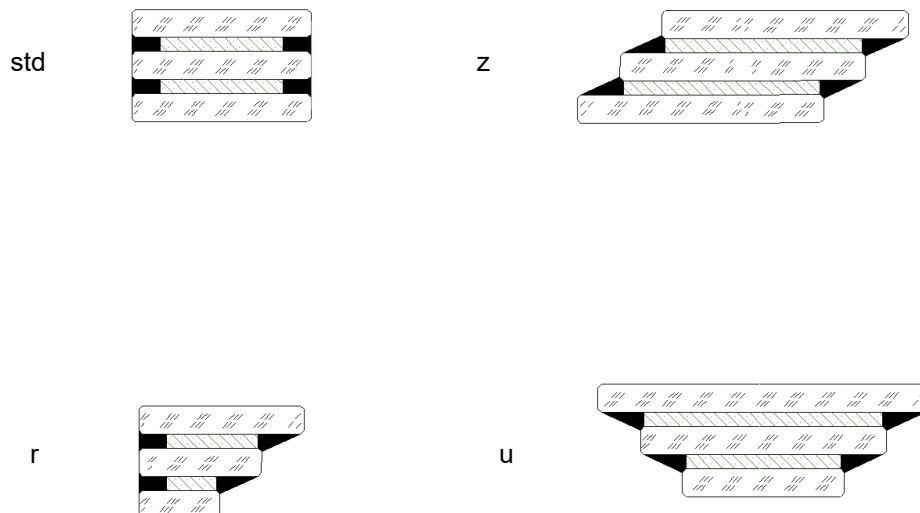

Figure 2 STS corner constructions

## 4.2 Handedness

Pyroguard SWS corner glasses are not symmetrical owing the requirement to glaze with a certain edge orientated down. This means that Pyroguard SWS are not symmetrical and cannot be flipped on site; they have a 'handedness'.

Therefore, to try to avoid errors in production, orders for corner butt-joint glasses will not be taken without installation drawings giving precise dimensions and 'handedness' of the r construction types.

These drawings must be signed off and agreed with the installer.

#### 4.3 Dimensions

The dimensions in orders should reflect the total width of each piece, not the individual panes (see Figure 3).

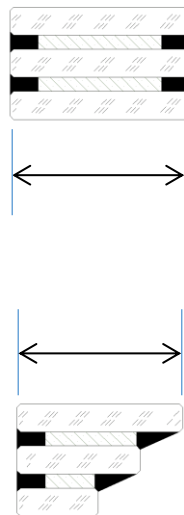

*Figure 3 Dimensions*

When calculating dimensions, please also consider the corner joint and the presence of the intumescent. Subtract 16 mm from the desired size (see Figure 4).

For angles other than 180° and 90° consult Pyroguard before ordering.

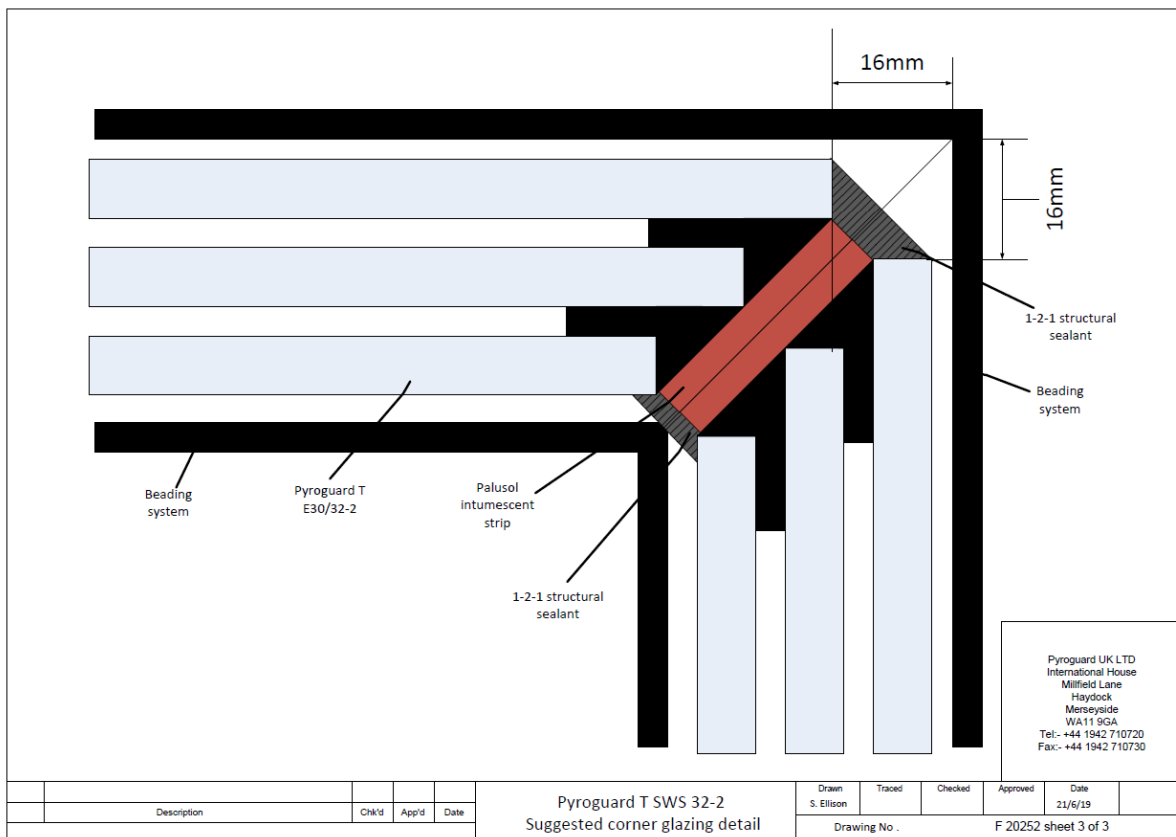

Figure 4 Technical drawing of 90° SWS corner joint detail illustrating subtract 16 mm rule

# 5 Installation

This installation guide provides instructions that will assist Pyroguard Infinity installers to construct a structural wall for all fire resistance classifications claimed. The installer must verify the application conditions for the building in advance. The assembly of Pyroguard Infinity glazing shall only be performed by suitably trained specialist staff. This document does not fully constitute a training document.

In the building exterior envelope or in an atria; which are both subject to the influences of sun, wind and weather, the function of the joints and glazing may vary from that under normal interior conditions. Seek technical approval from the sealant supplier and Pyroguard UK Ltd before planning such an installation.

Furthermore, the function in case of fire cannot be insured if the installation deviates from that described in this document. Only the recommended types of sealants, which have been fire tested in conjunction with the glazing and materials, are approved to be used for application with Pyroguard Infinity. Unfortunately, in the event of defects, the warranty shall be void with the use of other silicones, solvents, intumescent or other materials, or the disregard of generally recognised technical guidelines, or failure to follow these instructions. Additionally, Pyroguard do not warrant the installation or the structural safety of the installation, only the glass itself according to product standard EN14449.

The recommendations for application of sealant are given; these are to be followed by the installer.

Pyroguard Infinity panes are often of considerable weight and of large dimensions and must therefore be handled according to industry guidelines (refer to the Glass and Glazing Federation for details), to ensure they are installed without any damage and within regional safety at work guidelines

## 5.1 Pyroguard T installation instructions

1. Thoroughly clean all glass edges to be sealed. Remove any excess edge sealant with a blade and 0000 steel wool. Clean glass edges with white spirit.
2. Stick Palusol intumescent tape on both vertical edges according to the approval. Dowsil 895 (DOW CORNING) can be used to help adhere the tape. Stagger the joints in the tape rather than have them coincide. Make sure that the tape is centred.
3. Install the glass panels on setting blocks and adjust into an adjacent position.

4. In the event of bowing, glass will often straighten if left some time, otherwise, the glass panels can be adjusted into parallel position using slight and constant pressure in the direction of the glass surfaces.
5. Apply the approved sealant into the joint (typically Dowsil 895). Remove any excess sealant and smooth as necessary. Try not to contaminate the surface of the glass, as this can be difficult to remove. Use masking tape. Use the two-cloth cleaning method to clean the glass surface (see section 5.4) of any overspill.

An adhesive sticker placed on the glass indicates that this corner must be glazed this side down. For warranty reasons, it is imperative to follow this instruction.

- Glaze the Pyroguard glass with the stamp installed at the bottom edge (see example sticker in Figure 5).

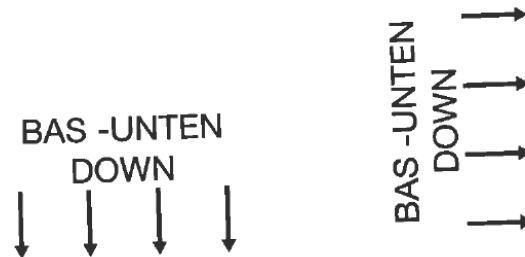

Figure 5 Label indicating orientation of glazing; this corner down.

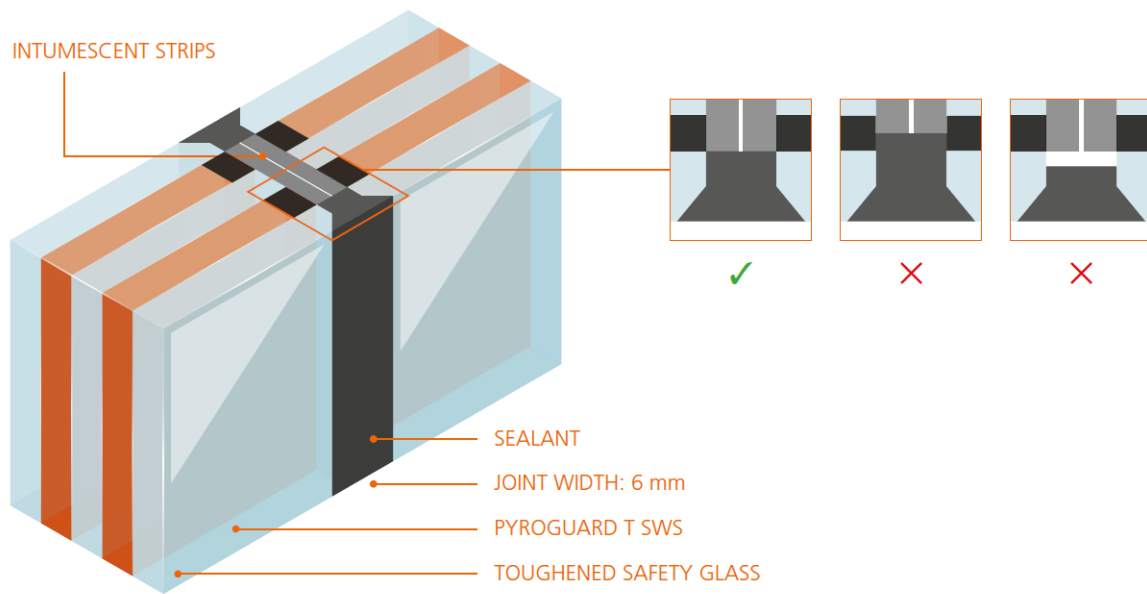

Figure 6 Installation of Pyroguard T SWS

## 5.2 Pyroguard EI (aka Pyroguard Rapide Plus) installation instructions

### Approved Materials for the glass-glass joint

- Interdens glazing tape from KuhnOdice UK Ltd
- Wet seal Kerafix Fire Rated Silicone (KuhnOdice UK Ltd)
- Aluminium (PAL type) edge tape

### Instructions

1. Ensure aluminium glazing tape is intact at glass edge
2. Apply Interdens glazing tape to both vertical glass edges (on top of aluminium glazing tape) making sure that it is centred.
3. Bring glass together, position using slight and constant pressure in the direction of the glass surfaces so that there is no airspace between Interdens layers.
4. Apply Kerafix silicone sealant (KuhnOdice UK Ltd) into the joint. This sealant is available in clear, black, and grey. Remove any excess sealant and smooth as necessary.

5. Immediately remove any excess silicone sealant from glass surface using the two-cloth cleaning method (see section 5.4).

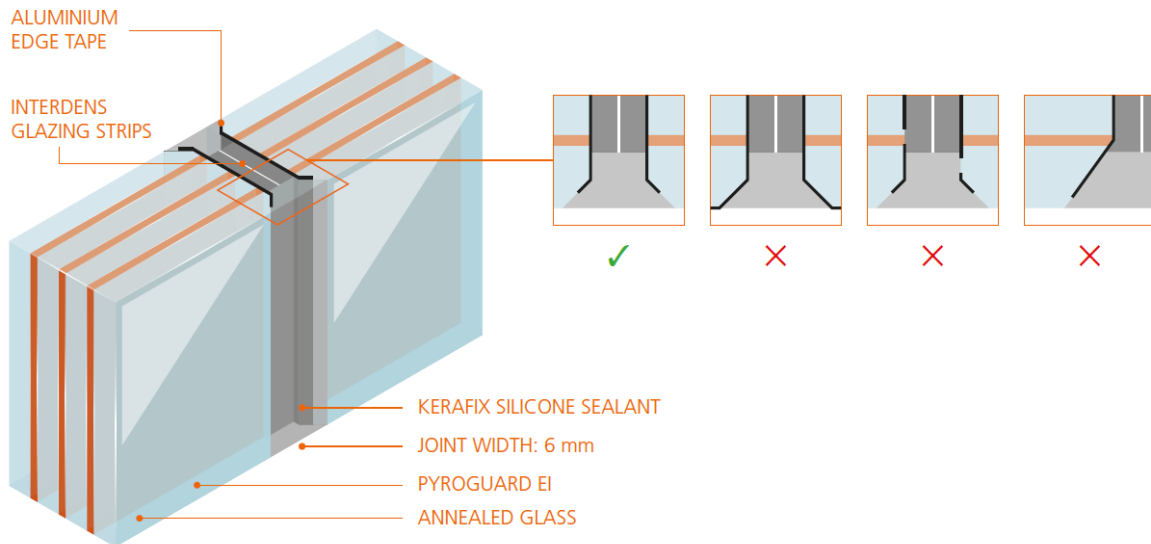

Figure 7 Installation of Pyroguard EI SWS

#### Notes

**Note 1:** Applicable butt-joint systems and corresponding Interdens glazing strip:

- 2 mm x 10 mm Interdens (KuhnOdice UK Ltd) with Pyroguard EI30 INT - 15 mm
- 2 mm x 10 mm Interdens (KuhnOdice UK Ltd) with Pyroguard EI30 EXT - 19 mm
- 2 mm x 15 mm Interdens (KuhnOdice UK Ltd) with Pyroguard EI60 INT - 23 mm
- 2 mm x 20 mm Interdens (KuhnOdice UK Ltd) with Pyroguard EI60 EXT - 27 mm

**Note 2:** Ensure the aluminium tape is not damaged or has become unadhered

**Note 3:** Use only the approved Kerafix silicone sealant (KuhnOdice UK Ltd) in the joint

**Note 4:** Aluminium tape should not be visible once the joint is complete

### 5.2.1 Handling instructions

Glass panels must be carefully handled using suitable glass handling and/or vacuum-lifting equipment.

Glazing installation must be performed in strict accordance with the installation instructions. Any change in materials or dimensions will result in loss of warranty.

The aluminium tape **is not to be removed or damaged** prior to installation. If it is damaged during installation, it should be removed and replaced.

An example of our handling instruction sticker applied to Pyroguard EI prior to dispatch can be found below.

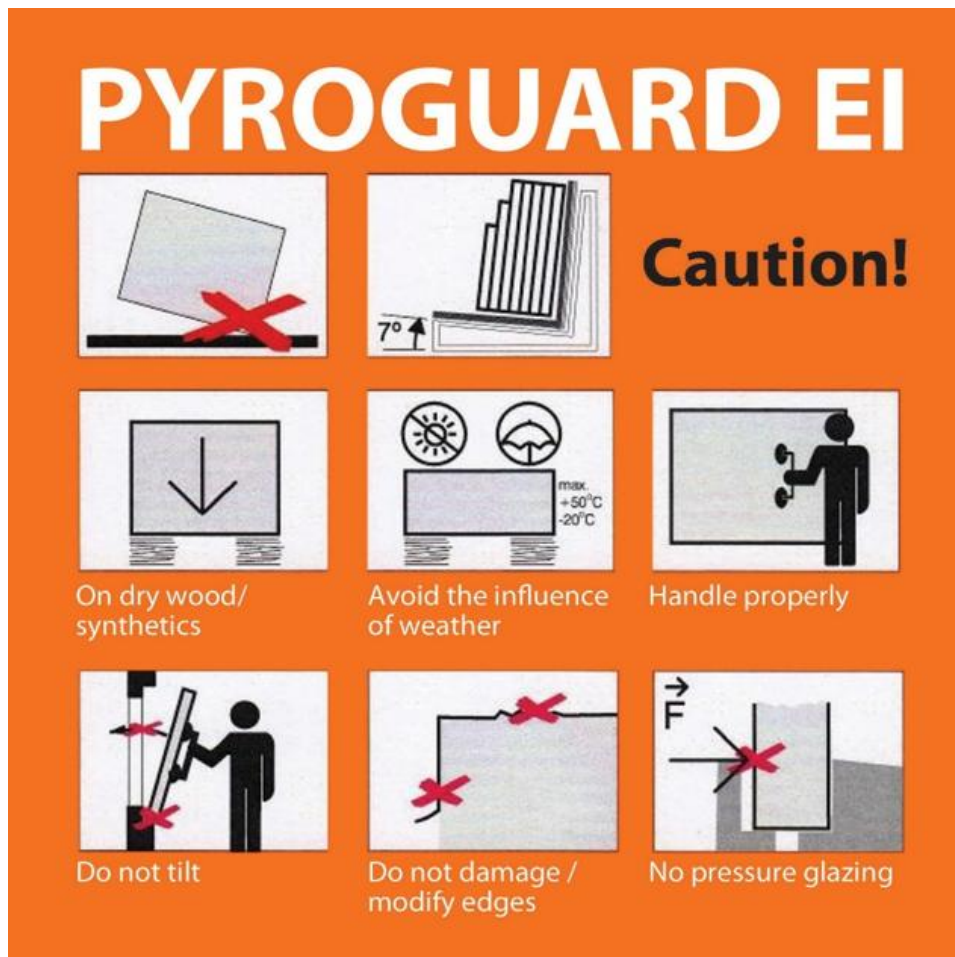

Please ensure these guidelines are adhered to during handling and installation.

## 5.2.2 Recommendations when taping the edges

Tape must always be applied to Pyroguard EI to avoid water damage in transport and in normal use of the product. Only Pyroguard recommended aluminium tape (PAL type) should be used to tape the edges of the cut sized glass.

For more detailed information, please consult the Pyroguard Operating Procedure Edge Taping guide at: <https://www.pyroguard.eu/downloads/our-guidance-documentation/>

## 5.3 Choosing sealants

The sealants listed in these documents cannot be substituted for near equivalents unless a specific choice of sealant has been approved. In this case, choose the sealant most suitable to the installation site.

### 5.3.1 Dowsil 121 Structural Glazing Sealant (DOW CORNING)

Dowsil 121 Structural Glazing Sealant (DOW CORNING) is a two-part, fast-cure, neutral-curing silicone sealant intended for structural bonding without the need of a two-part pump. It is ideal for repairs and/or replacement of structurally glazed glass and other substrates, for on-site structural glazing and in-shop structural glazing where the use of a two-part pump is not viable. It is supplied in dual-cartridge kits and is available in black and grey.

### 5.3.2 Dowsil 895 High Quality Structural Glazing Sealant (DOW CORNING)

One component silicone sealant Dowsil 895 (DOW CORNING) for structural glazing. Designed specifically for the structural bonding of glass, metal, and other building components. Meets the newly developed European Standards for structural glazing application, as developed by EOTA. Excellent adhesion. Odourless and non-corrosive cure system. One-component product resistant to ozone and temperature extremes. It is supplied in a single cartridge, and is available in black, white and grey.

### 5.3.3 Kerafix® Fire Rated Silicone (KunhOdice UK Ltd)

Kerafix® Fire-rated silicone is a flame-retardant, neutral curing single component sealant for indoor and outdoor use. The material is weather resistant, elastic and has excellent adhesion properties. It is supplied in a single cartridge, and it is available in black, white and grey.

### 5.4 Two cloth cleaning method (ref 'Dow Corning Americas Technical Manual')

“Two-Cloth” Cleaning Method. Clean, soft, absorbent, lint-free cloths, along with the appropriate choice of solvent, must be used to remove excess sealant from the substrate surface. The “two-cloth” cleaning method consists of a solvent wipe followed by a dry cloth wipe to lift and remove the solvent and contaminants suspended in the solvent. Multiple cleanings may be required to properly clean a substrate.

1. Pour or dispense an acceptable cleaning-grade solvent onto the cloth. A plastic (solvent-resistant) squeeze bottle works best for organic cleaning solvents. Do not dip the cloth into the container of solvent, as this will contaminate the cleaning agent.
2. Wipe vigorously to remove contaminants. Check the cloth to see if it has picked up contaminants. Rotate the cloth to a clean area and re-wipe until no additional dirt is picked up.
3. Immediately wipe the cleaned area with a separate clean, dry cloth before the solvent has evaporated. This technique will allow dirt and contaminants suspended in the solvent to be lifted and removed with the second dry cloth. Multiple cleanings may be required to adequately clean a substrate. Organic solvent must be removed with the dry cloth before the solvent evaporates or the cleaning will be less effective. Some surfaces or weather conditions will allow a small amount of residual organic solvent to remain. If this is the case, the surface must be allowed to dry before continuing with the sealant installation.

## 6 Disclaimer

The configurations mentioned in these documents shows materials/products that Pyroguard UK Ltd has successfully used in its own fire tests. Nevertheless, Pyroguard UK Ltd does not guarantee durability, tightness, fitness, or quality of the joint when using the shown materials/products. Pyroguard UK Ltd highly recommends that customers carry out their own tests to verify the durability, tightness, fitness, or quality of the joint.

Pyroguard's TechLibrary summarises the approved glazing, glazing dimensions and approved framing system/glazing assembly. All dimensions are given in millimetres (mm) unless otherwise stated. All glass dimensions are given width first and height second. All glass sizes are maximum allowable dimensions and either/both dimensions may be reduced but not increased. Where a 'max area' is shown the glass size may be taken to the maximum dimension in either width or height as long as the size used for the second dimension does not take it above the maximum area allowed. Where no maximum area is shown then both dimensions may be taken to the maximum allowed.

To fully comply with the approval, the original document referenced should be studied. All components of the glazing assemblies installed must be as described in the original test reports, classification reports, national approvals, global assessments, or other certification. If there is an option given in the assembly drawing for any of the components used in the glazing assembly then only the options given can be used.

Pyroguard's TechLibrary is provided for information purposes only. The information contained in this platform is offered for assistance in the applications of Pyroguard UK Ltd.'s products. Pyroguard UK Ltd may change the contents hereof without notice. The TechLibrary is not warranted to be error-free, nor subject to any other warranties or conditions, whether expressed orally or implied in law, including implied warranties and conditions of merchantability or fitness for a particular purpose. Pyroguard UK Ltd specifically disclaims any liability with respect to this platform and no contractual obligations are formed either directly or indirectly by this document. The technologies, functionality, services, and processes described herein are subject to change without notice.

Please contact your Pyroguard representative to access the TechLibrary.

## 7 Warranty

Pyroguard UK Ltd. warrants that its products will be free of substantial obstruction of vision from dust or other foreign substances due to defective materials or workmanship for a period of ten years from the date of delivery. Full details of the limited 10-year warranty are available on request.



## **Pyroguard UK Ltd**

Headquarters - International House  
Millfield Lane - Haydock - St. Helens  
Merseyside - WA11 9GA - United Kingdom

**T:** +44 (0) 1942 710 720

**E:** [info@pyroguard.eu](mailto:info@pyroguard.eu)

[www.pyroguard.eu](http://www.pyroguard.eu)

 [twitter.com/pyroguard](https://twitter.com/pyroguard)

 [linkedin.com/company/pyroguard](https://linkedin.com/company/pyroguard)

 [facebook.com/pyroguarduk](https://facebook.com/pyroguarduk)

 [instagram.com/pyroguard](https://instagram.com/pyroguard)

 [Pyroguard](https://www.youtube.com/Pyroguard)

**Pyroguard France SARL** - Parc d'activités communautaire n°1

145 rue des Roseaux - 57455 Seingbouse - France

**T:** +33 (0)3 87 00 28 15 **F:** +33 (0)3 87 00 28 11 **E:** [info.france@pyroguard.eu](mailto:info.france@pyroguard.eu)

**Pyroguard Netherlands B.V.** - ESP 260 C - 5633

AC Eindhoven - The Netherlands

**T:** +31 (0) 40 2888 525 **E:** [info.nl@pyroguard.eu](mailto:info.nl@pyroguard.eu)